

Braukmann V5007

Kombi-PICV

Pressure Independent Balancing and Control Valve

Application

The V5007 is a Pressure Independent Control Valve (PICV). It combines a flow controller and a full stroke, full authority temperature controller in one valve.

Equipped with an actuator Kombi-PICV provides a full stroke modulating temperature control.

It is suitable for use in variable and constant flow systems.

They may be used as constant flow limiter in constant flow systems (without an actuator) or as a Pressure Independent Control Valve in variable flow systems.

V5007 is typically used for balancing and temperature control of fan coil units, chilled ceilings and one-pipe heating systems. It is not intended for a potable water control.

Special Features

- Automatic balancing of differential pressure
 - Precise pressure independent flow performance
 - Highest energy saving potential due to efficient energy transfer and minimised pump speed
 - Measuring possibility to find the optimal setpoint for the pump
 - Versions with or without measuring connections available
 - Reduced movements of actuators as pressure fluctuation do not influence the required temperature
 - No complex calculation needed for selection
 - No balancing method needed for commissioning
 - Equal-percentage characteristics when used with modulating actuator
 - Wide range of application
 - Sizes DN15 to DN50 cover all popular sizes on Fan Coil Units various versions to support standard flow rates as well as low flow and high flow needs
 - Covers hydronic balancing and temperature control in one valve thus reducing mounting costs
 - Easy commissioning
 - Presetting with visual flow scale indicating directly the preset cubic meters per hour
 - Presetting using standard tool (wrench)
 - Can balance a system even if only some parts of a building are in operation
 - Maintenance friendly
 - Emergency shut-off function with plastic cap – not for permanent use, maximum 6 bars one side overpressure
- Draining and cleaning by opening of diaphragm area
 - Flow measuring possibility for problematic applications (only with versions having measuring connections)
 - Dirt resistant – no dead zones in the valves. Continuous flow assures self-cleaning effects. Ability to flush the diaphragm area



V5007T(Z/N)10



V5007T(Z/N)20



V5007T(Z/N)10(32/40/50)

Valve Efficiency

	low				high
Energy efficiency	●	●	●	●	●
Commissioning effort	●	●	○	○	○
Calculation effort	●	●	○	○	○

Technical Data

Media	
Medium:	Water with max. 50 % glycol according to VDI 2035 (up to 50 % Glycol)
pH-value:	8 - 9.5
Pressure values	
Max. operating pressure:	max. 25 bar for V5007T(Z/N)10... max. 16 bar for V5007T(Z/N)20... variants
Differential pressure range:	see table "K _v -values for measurement"
Δp_{min}	
Δp_{max}	600 kPa (6 bar)
Operating temperatures	
Max. operating temperature medium:	-10 to 120 °C (14 - 248 °F) ¹

Connections/Sizes	
Nominal size:	DN15 - DN50
Specifications	
Flow values:	see table "K _v -values for measurement"
Leakage:	According to Class IV IEC 60534-4 (up to 6 bar differential pressure)
k _{vs} (c _{vs})-value:	see table "K _v -values for measurement"
Pressure accuracy:	+/- 10 % of actual preset value in ideal conditions for presetting higher than 20 % of maximum

1. In case of usage above 90 °C discuss the application with customer care

Construction

V5007T(Z/N)10... variants

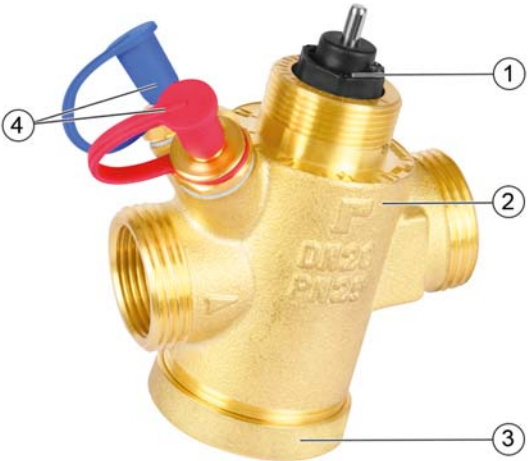
Overview	Components	Materials	
	1	Hexagon for presetting the valve. Easy presetting by standard tool (SW19)	High performance polymer
	2	Valve housing for internal and external threads (V5007TZ... variant) and internal threads (V5007TN... variant)	Dezincification-resistant brass
	3	Metallic cover with draining connection secured by nut allows PN25	Dezincification-resistant brass
	4	Two SafeCon™ pressure test valves for measuring using venturi effect	Dezincification-resistant brass
Not depicted components:			
	Valve insert with diaphragm assembly	High resistant polymer with EPDM diaphragm and stainless steel components	
	Sealings	EPDM	
	Presetting parts	High resistant polymer and brass	
	Inner parts	Brass, stainless steel, high resistant polymer and EPDM	
	Installation and setup instructions	Paper	

V5007T(Z/N)20... variants

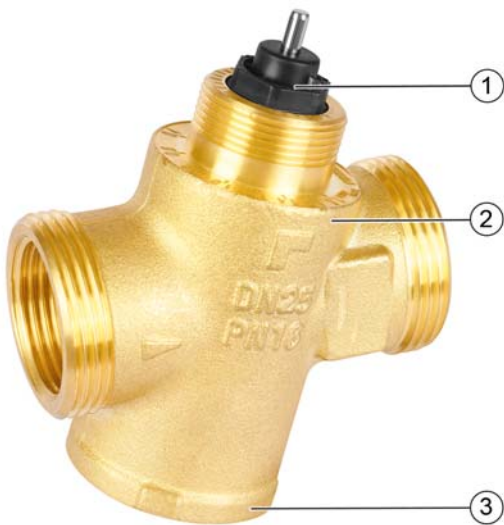
Overview	Components	Materials	
 <p>The image shows a brass valve assembly with three ports. A black hexagonal actuator is on top, labeled 1. The main valve body is labeled 2. A PPS cover is on the side, labeled 3. The valve has 'DN25 PN16' stamped on it.</p>	1	Hexagon for presetting the valve. Easy presetting by standard tool (SW19)	High performance polymer
	2	Valve housing for internal and external threads (V5007TZ... variant) and internal threads (V5007TN... variant)	Dezincification-resistant brass
	3	PPS cover with stainless c-clip having high rust resistance (allows PN16)	High performance polymer and stainless steel
	Not depicted components:		
		Valve insert with diaphragm assembly	High resistant polymer with EPDM diaphragm and stainless steel components
		Sealings	EPDM
	Presetting parts	High resistant polymer and brass	
	Inner parts	Brass, stainless steel, high resistant polymer and EPDM	
	Installation and setup instructions	Paper	

V5007T(Z/N)10(32/40/50)... variants

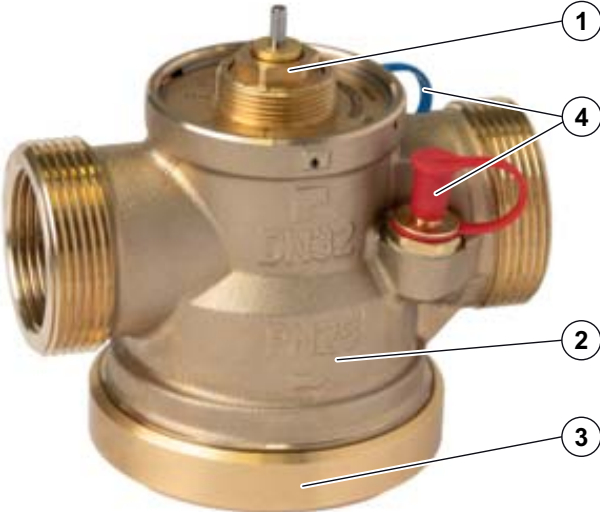
Overview	Components	Materials	
 <p>The image shows a larger brass valve assembly with four ports. A hexagonal actuator is on top, labeled 1. The main valve body is labeled 2. A metallic cover with a red handle is on the side, labeled 3. Two pressure test valves are on the side, labeled 4. The valve has 'DN32 PN25' stamped on it.</p>	1	Hexagon for presetting the valve. Easy presetting by standard tool (SW19)	Dezincification-resistant brass
	2	Valve housing for internal and external threads (V5007TZ... variant) and internal threads (V5007TN... variant)	Dezincification-resistant brass
	3	Metallic cover with draining connection secured by nut allows PN25	Dezincification-resistant brass
	4	Two SafeCon™ pressure test valves for measuring using venturi effect	Dezincification-resistant brass
	Not depicted components:		
		Valve insert with diaphragm assembly	EPDM diaphragm and stainless steel components
	Sealings	EPDM	
	Presetting parts	Stainless steel	
	Inner parts	Brass, stainless steel and EPDM	
	Installation and setup instructions	Paper	

Method of Operation

The V5007 combines the functionality of a dynamic balancing valve and a control valve in one product.

The dynamic balancing function maintains a constant differential pressure over the control valve.

The control valve regulates the flow by means of a variable orifice which is controlled by the actuator (with the equal percentage characteristics of the control).

The constant differential pressure across the control valve ensures accurate control and full valve authority, independent of the pressure conditions in the system.

To adjust the maximum flow setting:

- 1) disengage actuator by removing actuator from valve or loosening the actuator nut while securing actuator
- 2) turn the hexagon to required flow setting
- 3) remount the actuator

Measurement

The V5007TN10... and V5007TZ10... variant of the valve enables two type measurement using pressure test valves. These measuring ports gets its pressure on the inner orifice, which is only dependent on the presetting of the valve and thus not changing with the differential pressure regulated on the valve. One of the ports (+) is in front of the orifice, one is behind the inner orifice on the outlet of the valve. The measurement available is following:

Flow measurement

For the flow measurement the differential pressure measurement and the k_v -value correspondent to the presetting of the valve is necessary. The valve plug has to be in fully open position (i.e. the actuator has to be fully opened or not installed on the valve). K_v values are dependent on the position of the measurement points and the measurement may be influenced by the actual turbulence and flow conditions. The precision of the measurement may be affected. The differential pressure can be obtained by measurement on the pressure test valves according to the following schematics:

Flow rate can be calculated according to a following formula:

$$Q = kv \times \sqrt{\Delta p_Q}$$

Formula	Unit	Description
K_v	[l/h]	Coefficient obtained from following table (in accordance with actual presetting of the valve)
Δp_Q	[bar]	Measured differential pressure

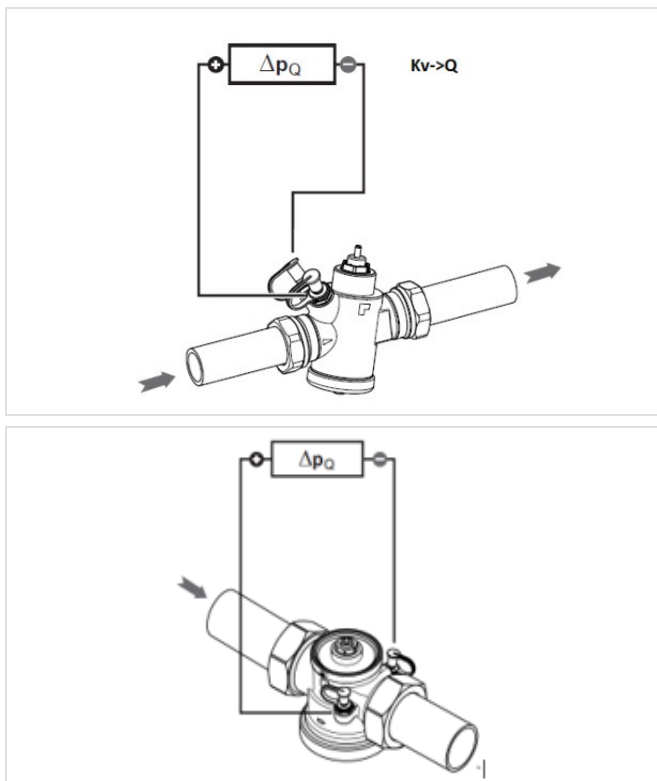



Fig. 1 Flow measurement

Differential pressure measurement

In case the overall differential pressure over the whole valve needs to be obtained, the additional accessory for measurement needs to be used which enables the pressure measurement in front of the valve (Measuring adapter with heat sink – see Item No. in the accessories section). The pressure measurement port on the accessory and  port on the valve (see Fig. 2) should be used for the measurement.

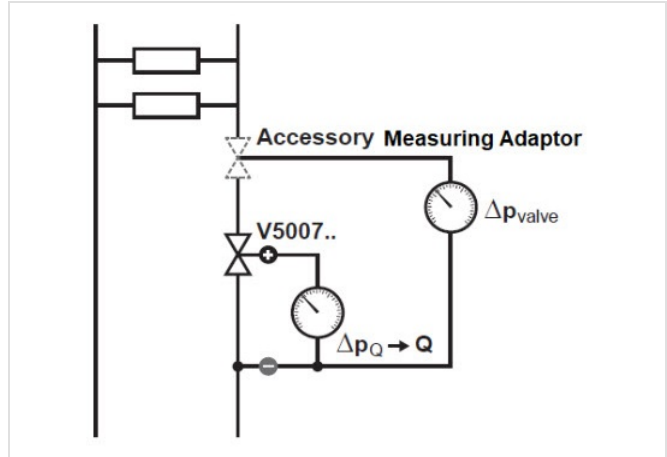

Fig. 2 Differential pressure measurement

Transportation and Storage

Keep parts in their original packaging and unpack them shortly before use.

The following parameters apply during transportation and storage:

Parameter	Value
Environment:	clean, dry and dust free
Min. ambient temperature:	5 °C
Max. ambient temperature:	60 °C
Min. ambient relative humidity:	5 % *
Max. ambient relative humidity:	90 % *

*non condensing

Technical Characteristics

Kv-values for measurement

DN	Flow range															Item No.		
	Min. flow (l/h)	Max. flow (l/h)																
15	10	350	Presetting	10	100	150	200	250	270	300	320	350	max.					V5007TZ10150350
			K _v -value	0.08	0.17	0.26	0.37	0.49	0.55	0.65	0.79	1.03						
15	120	1400	Presetting	120	300	400	600	700	800	1000	1200	1300	1400					V5007TZ10151400
			K _v -value	0.12	0.38	0.52	0.85	1.02	1.21	1.67	2.09	2.60	2.95					
20	80	1000	Presetting	80	300	400	500	600	700	800	900	1000						V5007TZ10201000
			K _v -value	0.19	0.40	0.56	0.73	0.92	1.17	1.44	1.66	2.04						
20	150	2000	Presetting	150	400	600	800	1000	1200	1400	1600	1800	2000					V5007TZ10202000
			K _v -value	0.21	0.47	0.78	1.13	1.57	2.09	2.56	3.45	4.81	6.03					
25	180	2000	Presetting	180	600	800	1000	1200	1400	1600	1800	2000						V5007TZ10252000
			K _v -value	0.27	0.87	1.51	2.29	3.27	3.88	4.20	3.60	3.38						
25	300	2700	Presetting	300	600	900	1200	1500	1800	2100	2400	2700	max.					V5007TZ10252700
			K _v -value	0.35	0.73	1.12	1.69	2.24	2.86	3.63	4.38	5.69	7.44					
32	500	4000	Presetting	500	1000	1250	1500	1750	2000	2250	2500	2750	3000	3250	3500	3750	4000	V5007TZ10324000
			K _v -value	1.51	1.88	2.29	2.77	3.3	4.08	4.54	5.25	6.01	6.83	7.71	8.65	9.64	10.7	
40	1000	7500	Presetting	1000	1500	2000	2500	3000	3500	4000	4500	5000	5500	6000	6500	7000	7500	V5007TZ10407500
			K _v -value	0.83	2.08	3.36	4.67	6.00	7.37	8.76	10.18	11.63	13.10	14.61	16.14	17.70	19.29	
50	2000	12000	Presetting	2000	3000	4000	5000	6000	7000	8000	9000	10000	11000	12000				V5007TZ105012000
			K _v -value	5.16	7.75	10.3	12.9	15.49	18.07	20.66	23.24	25.82	28.4	30.98				

Compatible actuators

DN	Stroke (mm)	MT4	MT8	M5410	M7410A	M4410	M7410E	M6410/ M7410C	M100	M6410	M7410E	Item No.
		4.0 mm, 90 N, on/off, Thermal	8.0 mm, 90 N, on/off, Thermal	8.0 mm, 90 N on/off	4.0 mm, 90 N, 3-point	4.0 mm, 100 N, Mod.	8.0 mm, 180 N, Mod.	8.0 mm, 180 N, 3-point	4.0 mm, 90 N, on/off, Thermal	8.0 mm, 300 N, 3-point	8.0 mm, 300 N, Mod.	
15	2.9	x			x	x			x			V5007TZ10150350
15	6.0		x	x			x*					V5007TZ10151400
15	2.9	x			x	x			x			V5007TN10150350
15	6.0		x	x			x*					V5007TN10151400
15	2.9	x			x	x			x			V5007TZ20150350
15	6.0		x	x			x*					V5007TZ20151400
15	2.9	x			x	x			x			V5007TN20150350
15	6.0		x	x			x*					V5007TN20151400
20	2.9	x			x	x			x			V5007TZ10201000
20	6.0		x	x			x*					V5007TZ10202000
20	2.9	x			x	x			x			V5007TN10201000
20	6.0		x	x			x*					V5007TN10202000
20	2.9	x			x	x			x			V5007TZ20201000
20	6.0		x	x			x*					V5007TZ20202000
20	2.9	x			x	x			x			V5007TN20201000
20	6.0		x	x			x*					V5007TN20202000
25	2.9	x			x	x			x			V5007TZ10252000
25	6.0		x	x			x*					V5007TZ10252700
25	2.9	x			x	x			x			V5007TN10252000
25	6.0		x	x			x*					V5007TN10252700
25	2.9	x			x	x			x			V5007TZ20252000
25	6.0		x	x			x*					V5007TZ20252700
25	2.9	x			x	x			x			V5007TN20252000
25	6.0		x	x			x*					V5007TN20252700
32	6.0						x	x				V5007TZ10324000
32	6.0						x	x				V5007TN10324000
40	6.0						x	x				V5007TZ10407500
40	6.0						x	x				V5007TN10407500
50	6.0									x	x	V5007TZ105012000
50	6.0									x	x	V5007TN105012000

Note: *To ensure compatibility the actuator pointer needs to be removed. (see picture "Remove actuator pointer")

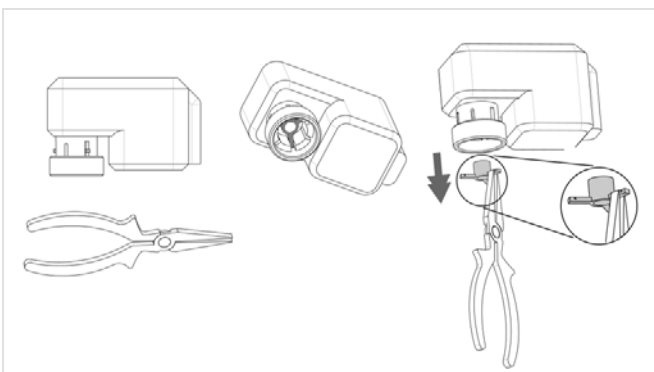
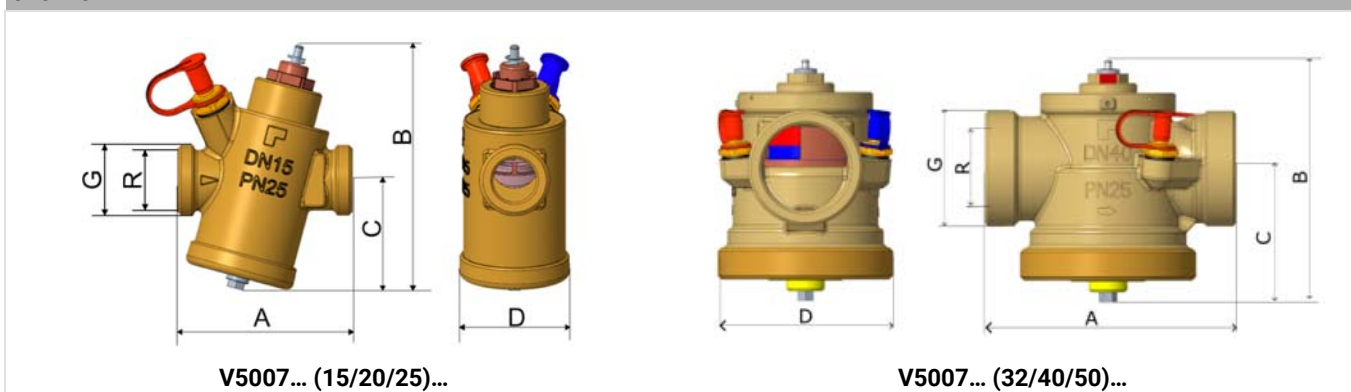

Fig. 3 Remove actuator pointer

Dimensions

Overview



Parameter		Value						
Nominal size diameter:	DN	15	20	25	32	40	50	
Dimensions:	A	75	79	83	130	130	158	
	B	105	105	105	123	124	136	
	C	47	47	47	69	69	72	
	D	48	48	48	91	91	99	
Thread internal:	V5007TZ.../ V5007TN...	R	Rp 1/2" (NPT1/2)	Rp 3/4" (NPT3/4)	Rp 1" (NPT1)	Rp 1 1/4" (NPT1-1/4)	Rp 1 1/2" (NPT1-1/2)	Rp 2" (NPT2)
Thread external:	V5007TZ... only	G	7/8"	1"	1 1/4"	1 3/4"	2"	2 1/2"

Ordering Information

The following tables contain all the information you need to make an order of an item of your choice. When ordering, please always state the type, the ordering or the part number.

Options

DN	Differential pressure range		Actuator stroke (closing dimension 11.5) [mm]	Item No. with measuring ports, European threads	Item No. without measuring ports, European threads	Item No. with measuring ports, internal NPT threads	Item No. without measuring ports, internal NPT threads
	$\Delta p_{min.}$ (kPa)	$\Delta p_{max.}$ (kPa)					
15	15	600	2.9	V5007TZ10150350	V5007TZ20150350	V5007TN10150350	V5007TN20150350
15	18		6	V5007TZ10151400	V5007TZ20151400	V5007TN10151400	V5007TN20151400
20	18		2.9	V5007TZ10201000	V5007TZ20201000	V5007TN10201000	V5007TN20201000
20	20		6	V5007TZ10202000	V5007TZ20202000	V5007TN10202000	V5007TN20202000
25	18		2.9	V5007TZ10252000	V5007TZ20252000	V5007TN10252000	V5007TN20252000
25	20		6	V5007TZ10252700	V5007TZ20252700	V5007TN10252700	V5007TN20252700
32	20		6	V5007TZ10324000	-	V5007TN10324000	-
40	20		6	V5007TZ10407500	-	V5007TN10407500	-
50	20		6	V5007TZ105012000	-	V5007TN105012000	-



Note: May vary with presetting of the valve \pm 10%

Note: For list of compatible actuator see the table on page 6

Accessories

	Description	Dimension	Item No.
	MT4	Actuator: 4.0 mm stroke, 90 N, on/off, thermoelectric	
			MT4-024-NO
			MT4-024-NO-2.5M
			MT4-024S-NO
			MT4-024-NC
			MT4-024-NC-2.5M
			MT4-024S-NC
			MT4-230-NO
			MT4-230-NO-2.5M
			MT4-230S-NO
			MT4-230-NC
			MT4-230-NC-2.5M
		MT4-230S-NC	
	MT8	Actuator: 8.0 mm stroke, 90 N, on/off, thermoelectric	
		NO = Normally open	24 V AC/DC
		NC = Normally closed	
		NO = Normally open	230 V AC
		NC = Normally closed	
			MT8-024-NO
			MT8-024-NC
			MT8-230-NO
			MT8-230-NC
	M5410	Actuator: 6.5 mm stroke, 100 N, on/off, fast motorized	
		Note: Closes when power fails	
			M5410C1001
			M5410L1001
	M7410A	Actuator: 4.0 mm stroke, 90 N, 3-point, on/off	
		Note: By use of this actuator series the max. flow of the valve is reduced by 15 %	
			M7410A1001
			M7410A1001-3M
	M4410	Actuator: 4.0 mm stroke, 100 N, modulating, thermoelectric 0 - 10 V	
		Note: Closes when power fails	
			M4410E1510
			M4410K1515
			M4410C4000
			M4410C4500
			M4410C4540
			M4410L4000
			M4410L4500
			M4410L4540
	M7410E	Actuator: 8 mm stroke, 180 N, 0/2 - 10 V, modulating	
		Note: To ensure compatibility the actuator pointer needs to be removed. (see picture "Remove actuator pointer" in chapter "Compatible actuators")	
			M7410E1002
	M7410E	Actuator: 8.0 mm stroke, 300 N, modulating	
			M7410E1028
			M7410E2034
			M7410E4030

	M6410	Actuator: 6.5 mm stroke, 180 N, 3-point, floating		
		Manual override	24 V AC	M6410C2023
		Manual override, 2 auxiliary switches		M6410C4029
		Manual override	230 V AC	M6410L2023
	M6410	Actuator: 8.0 mm stroke, 300 N, 3-point, floating		
		Note: 300 N actuator only for DN50 variant		
				M6410C2031
				M6410C4037
	M7410C	Actuator: 6.5 mm stroke, 180 N, 3-point / floating		
			24 V AC	M7410C1007
	M100	Actuator: 4.0 mm stroke, 90 N, on/off, thermoelectric		
				M100-BO
				M100-BG
				M100-AO
				M100-AG
				M100-BOX
				M100-BGX
				M100-AOX
			M100-AGX	
	VM242A	BasicMes-2 handheld measuring computer		
		Computer is supplied with case and accessories	for all sizes	VM242A0101
	V2511A	Draining valve		
		Note: Available from October 2024.	DN15 - DN25	V2511A002
			DN32 - DN50	V2511A009
	VS2600	Spare set of 2 pressure test cocks G¹/₄"		
			for all sizes	VS2600C001
	V2511A	Insulation shell		
		Note: Available from October 2024.	DN15 - DN25	V2511A001
			DN32 - DN40	V2511A010
	V2512A	Fittings for external thread		
			DN 15, ⁷ / ₈ "	V2512A78

	<table border="1"> <tr> <th colspan="2">VST06A</th> <th colspan="2">Connection set</th> </tr> <tr> <td colspan="4">Threaded connections</td> </tr> <tr> <td colspan="2"></td> <td>DN 20, 3/4"</td> <td>VST06-3/4A</td> </tr> <tr> <td colspan="2"></td> <td>DN 25, 1"</td> <td>VST06-1A</td> </tr> </table>	VST06A		Connection set		Threaded connections						DN 20, 3/4"	VST06-3/4A			DN 25, 1"	VST06-1A																																								
VST06A		Connection set																																																							
Threaded connections																																																									
		DN 20, 3/4"	VST06-3/4A																																																						
		DN 25, 1"	VST06-1A																																																						
	<table border="1"> <tr> <th colspan="2">V2511A</th> <th colspan="2">Measuring adapter</th> </tr> <tr> <td colspan="4">Note: Available from October 2024.</td> </tr> <tr> <td colspan="2"></td> <td>DN15</td> <td>V2511A003</td> </tr> <tr> <td colspan="2"></td> <td>DN15 NPT</td> <td>V2511A004</td> </tr> <tr> <td colspan="2"></td> <td>DN20</td> <td>V2511A005</td> </tr> <tr> <td colspan="2"></td> <td>DN20 NPT</td> <td>V2511A006</td> </tr> <tr> <td colspan="2"></td> <td>DN25</td> <td>V2511A007</td> </tr> <tr> <td colspan="2"></td> <td>DN25 NPT</td> <td>V2511A008</td> </tr> <tr> <td colspan="2"></td> <td>DN32</td> <td>V2511A011</td> </tr> <tr> <td colspan="2"></td> <td>DN32 NPT</td> <td>V2511A012</td> </tr> <tr> <td colspan="2"></td> <td>DN40</td> <td>V2511A013</td> </tr> <tr> <td colspan="2"></td> <td>DN40 NPT</td> <td>V2511A014</td> </tr> <tr> <td colspan="2"></td> <td>DN50</td> <td>V2511A015</td> </tr> <tr> <td colspan="2"></td> <td>DN50 NPT</td> <td>V2511A016</td> </tr> </table>	V2511A		Measuring adapter		Note: Available from October 2024.						DN15	V2511A003			DN15 NPT	V2511A004			DN20	V2511A005			DN20 NPT	V2511A006			DN25	V2511A007			DN25 NPT	V2511A008			DN32	V2511A011			DN32 NPT	V2511A012			DN40	V2511A013			DN40 NPT	V2511A014			DN50	V2511A015			DN50 NPT	V2511A016
V2511A		Measuring adapter																																																							
Note: Available from October 2024.																																																									
		DN15	V2511A003																																																						
		DN15 NPT	V2511A004																																																						
		DN20	V2511A005																																																						
		DN20 NPT	V2511A006																																																						
		DN25	V2511A007																																																						
		DN25 NPT	V2511A008																																																						
		DN32	V2511A011																																																						
		DN32 NPT	V2511A012																																																						
		DN40	V2511A013																																																						
		DN40 NPT	V2511A014																																																						
		DN50	V2511A015																																																						
		DN50 NPT	V2511A016																																																						



Ademco 1 GmbH, Hardhofweg 40,
74821 MOSBACH, GERMANY
Phone: +49 6261 810

Manufactured for and on behalf of
Pittway Sàrl, Z.A., La Pièce 6,
1180 Rolle, Switzerland

Subject to change. EN0H-2150GE23 R0624
© 2024 Resideo Technologies, Inc.
All rights reserved.

For more information
resideo.com

This document contains proprietary information of Pittway Sàrl and its affiliated companies and is protected by copyright and other international laws. Reproduction or improper use without specific written authorization of Pittway Sàrl is strictly forbidden.

Summary table

DN	Flow range		Stroke	Presetting and Kv values (measured on PT valves)														Item No. (with measurement)	Item No. (without measurement - no PT valves)	Actuator Force (N)	Recommended actuators				
	Min. flow (l/h)	Max. flow (l/h)		10	100	150	200	250	270	300	320	350	max.	4 mm, 90 N actuators: MT4 , M100 (on/off thermal) M7410A (3-point) M4410 (Mod.)	8 mm, 90/180 N: MT8 (on/off, thermal) M5410 (on/off) M7410 (Mod.)*	8 mm, 180 N: M7410 (Mod.) M6410 (3-point) M7410C (3-point)	8 mm, 300 N: M6410 (3-point) M7410E (Mod.)								
15	10	350	2.9	Presetting	10	100	150	200	250	270	300	320	350	max.					V5007TZ10150350	V5007TZ10150350	90/180	X	-	-	-
				K _V -value	0.08	0.17	0.26	0.37	0.49	0.55	0.65	0.79	1.03					V5007TN10150350	V5007TN10150350	-		X	-	-	
120	1400	6	Presetting	120	300	400	600	700	800	1000	1200	1300	1400					V5007TZ10151400	V5007TZ10151400	-		X	-	-	
			K _V -value	0.12	0.38	0.52	0.85	1.02	1.21	1.67	2.09	2.60	2.95					V5007TN10151400	V5007TN10151400	X		-	-	-	
20	80	1000	2.9	Presetting	80	300	400	500	600	700	800	900	1000					V5007TZ10201000	V5007TZ10201000	-		X	-	-	
				K _V -value	0.19	0.40	0.56	0.73	0.92	1.17	1.44	1.66	2.04					V5007TN10201000	V5007TN10201000	-		X	-	-	
150	2000	6	Presetting	150	400	600	800	1000	1200	1400	1600	1800	2000					V5007TZ10202000	V5007TZ10202000	X		-	-	-	
			K _V -value	0.21	0.47	0.78	1.13	1.57	2.09	2.56	3.45	4.81	6.03					V5007TN10202000	V5007TN10202000	-		X	-	-	
180	2000	2.9	Presetting	180	600	800	1000	1200	1400	1600	1800	2000					V5007TZ10252000	V5007TZ10252000	X	-		-	-		
			K _V -value	0.27	0.87	1.51	2.29	3.27	3.88	4.20	3.60	3.38					V5007TN10252000	V5007TN10252000	-	X		-	-		
300	2700	6	Presetting	300	600	900	1200	1500	1800	2100	2400	2700	max.					V5007TZ10252700	V5007TZ10252700	-		X	-	-	
			K _V -value	0.35	0.73	1.12	1.69	2.24	2.86	3.63	4.38	5.69	7.44					V5007TN10252700	V5007TN10252700	-		-	X	-	
500	4000	6	Presetting	500	1000	1250	1500	1750	2000	2250	2500	2750	3000	3250	3500	3750	4000	V5007TZ10324000		180	-	-	X	-	
			K _V -value	1.51	1.88	2.29	2.77	3.3	4.08	4.54	5.25	6.01	6.83	7.71	8.65	9.64	10.7	V5007TN10324000			-	-	X	-	
1000	7500	6	Presetting	1000	1500	2000	2500	3000	3500	4000	4500	5000	5500	6000	6500	7000	7500	V5007TZ10407500		300	-	-	X	-	
			K _V -value	0.83	2.08	3.36	4.67	6.00	7.37	8.76	10.18	11.63	13.10	14.61	16.14	17.70	19.29	V5007TN10407500			-	-	X	-	
2000	12000	6	Presetting	2000	3000	4000	5000	6000	7000	8000	9000	10000	11000	12000					V5007TZ105012000		-	-	-	X	
			K _V -value	5.16	7.75	10.3	12.9	15.49	18.07	20.66	23.24	25.82	28.4	30.98					V5007TN105012000		-	-	-	X	

* Comment - the pointer of M7410 for these valves needs to be removed by installer